



US 20110115772A1

(19) **United States**

(12) **Patent Application Publication**  
**Chung**

(10) **Pub. No.: US 2011/0115772 A1**

(43) **Pub. Date: May 19, 2011**

(54) **PIXEL CIRCUIT AND ORGANIC ELECTROLUMINESCENT DISPLAY APPARATUS USING THE SAME**

(52) **U.S. Cl. .... 345/211; 345/76**

(57) **ABSTRACT**

(76) **Inventor: Kyung-Hoon Chung, Yongin-City (KR)**

An improved pixel circuit is provided. The pixel circuit includes a light emitting device driven by a drive current according to a voltage applied to a gate electrode of a driving transistor. The pixel circuit also includes a first capacitor, a second transistor for transferring a data signal to a first terminal of the first capacitor in response to a scan control signal applied to a gate electrode of the second transistor, a third transistor for diode-connecting the driving transistor in response to a scan control signal applied to a gate electrode of the third transistor, a fourth transistor for applying a first power voltage to the first electrode of the driving transistor in response to an emission control signal, and a fifth transistor for applying a sustain voltage to a first terminal of the first capacitor in response to the emission control signal. The driving transistor and the second to fifth transistors are N-type transistors.

(21) **Appl. No.: 12/832,935**

(22) **Filed: Jul. 8, 2010**

(30) **Foreign Application Priority Data**

Nov. 16, 2009 (KR) ..... 10-2009-0110361

**Publication Classification**

(51) **Int. Cl.**  
**G09G 3/30** (2006.01)  
**G09G 5/00** (2006.01)

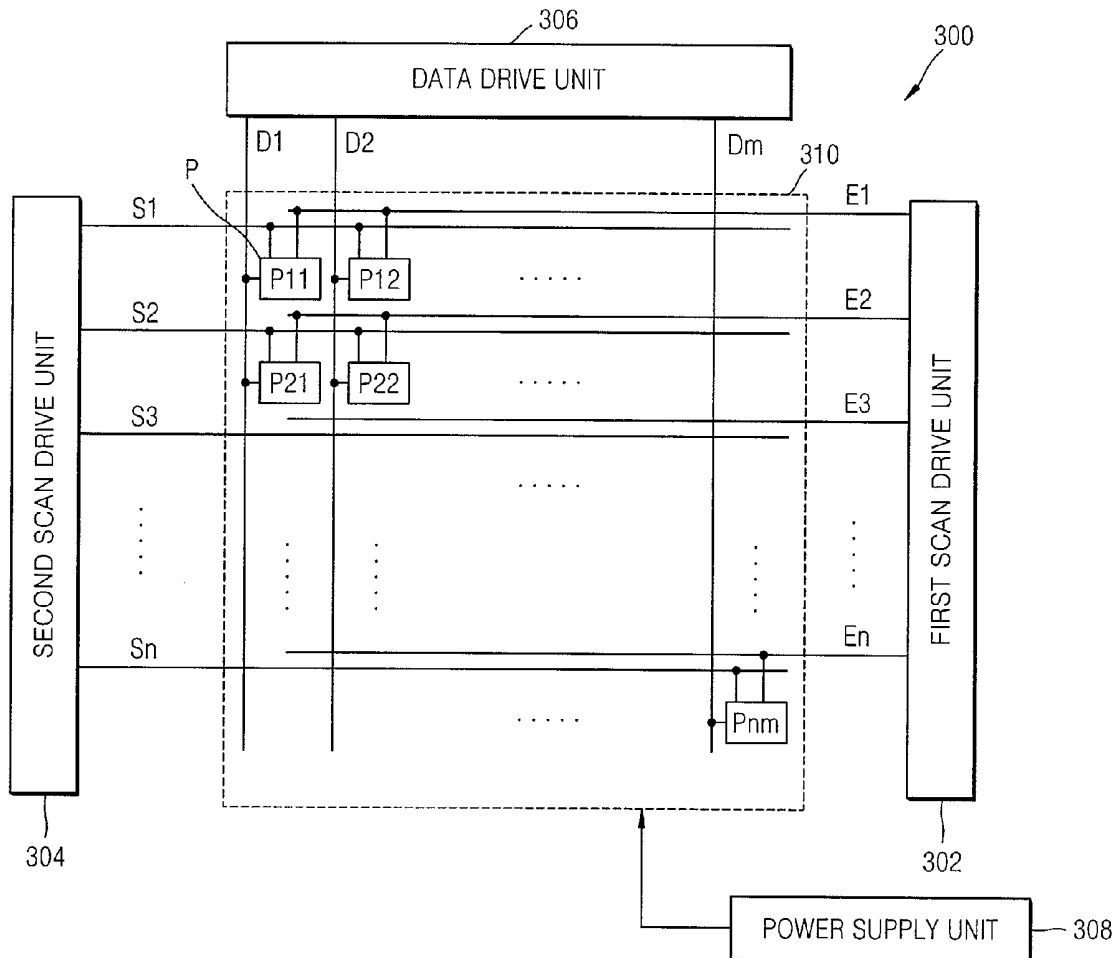

FIG. 1

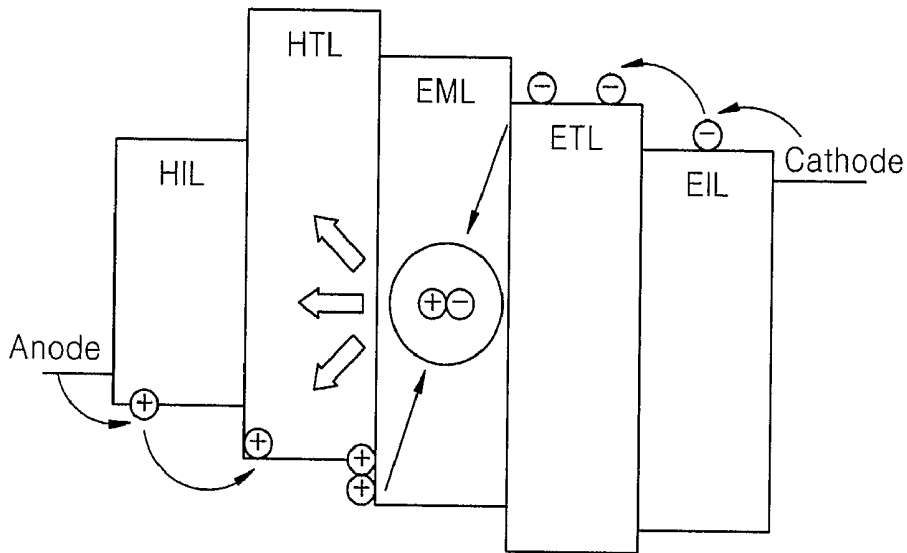

FIG. 2

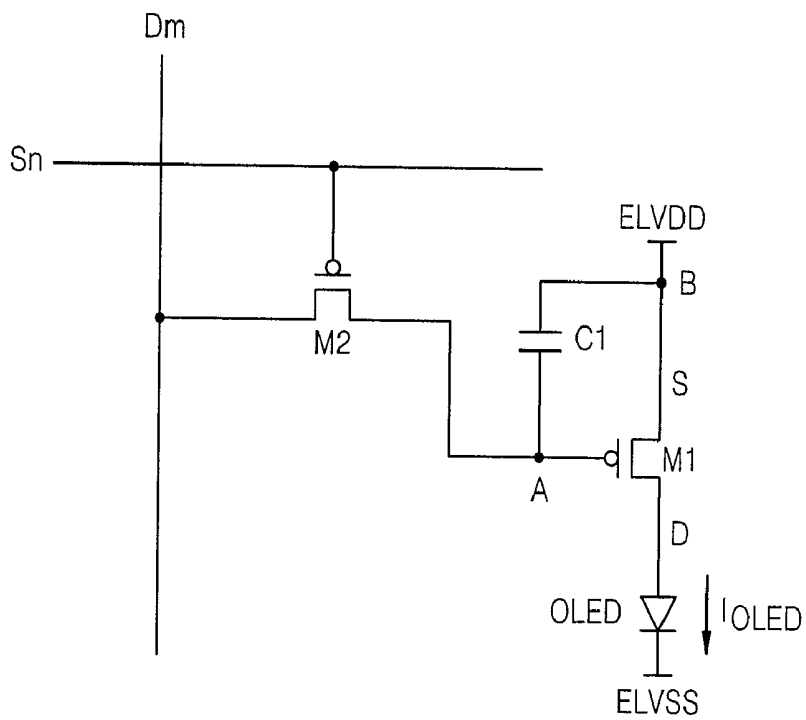

FIG. 3

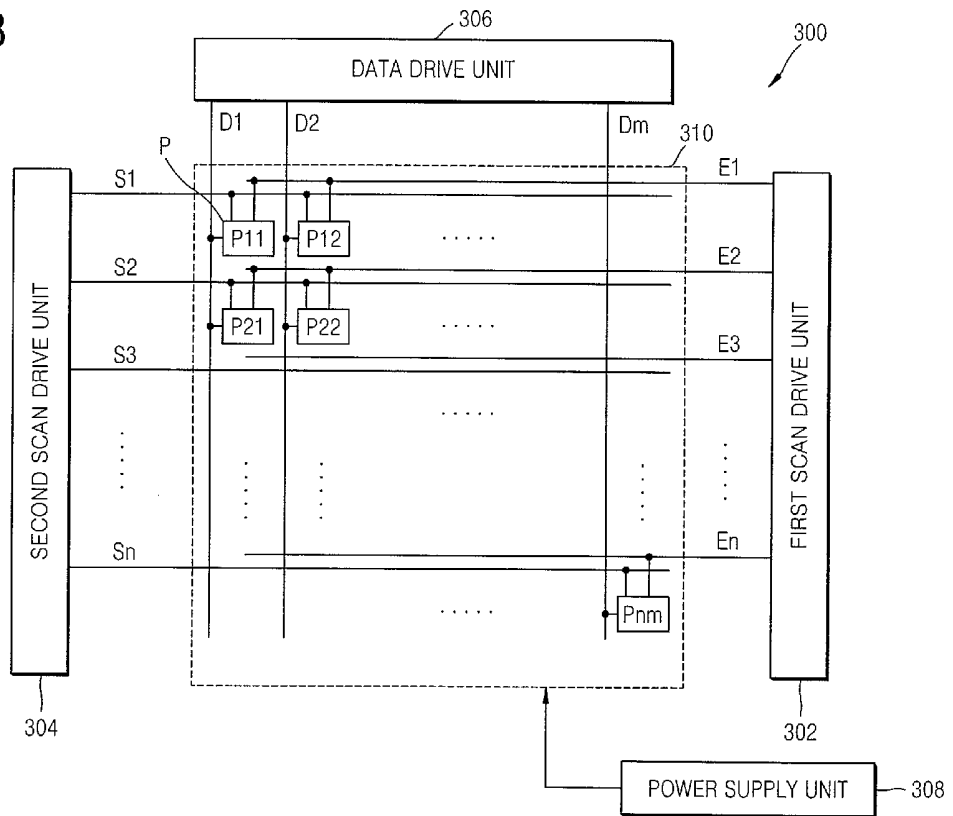

FIG. 4

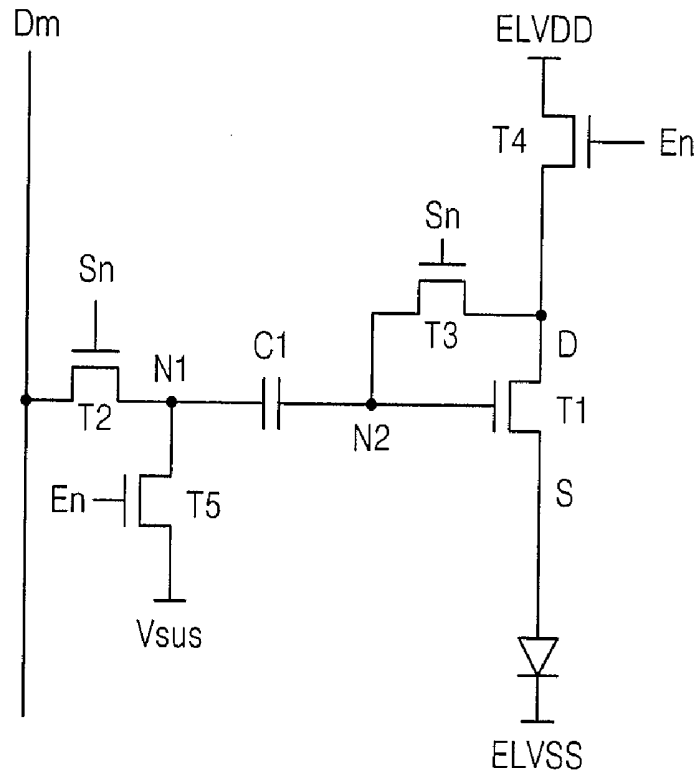

FIG. 5

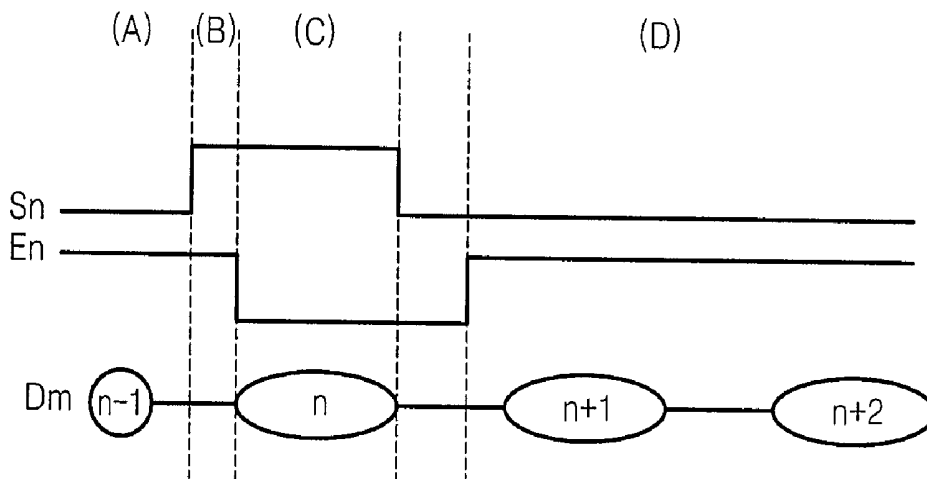

FIG. 6

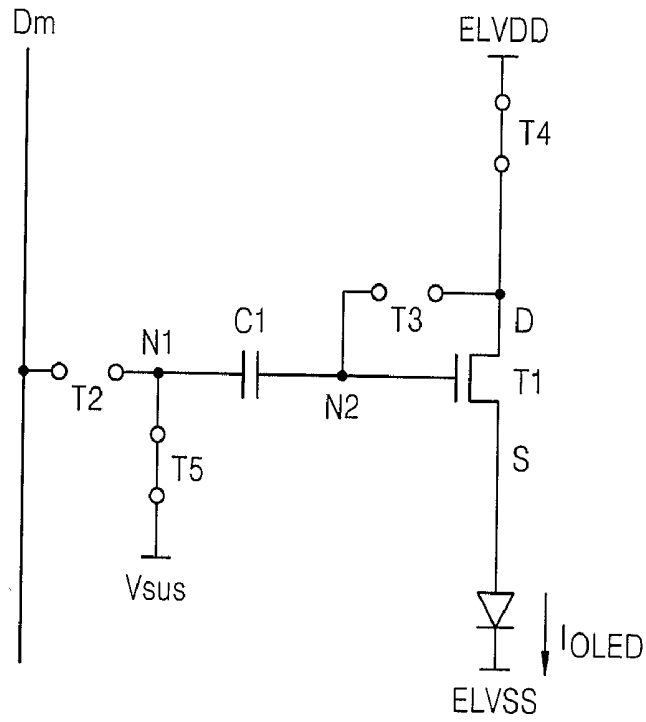

FIG. 7

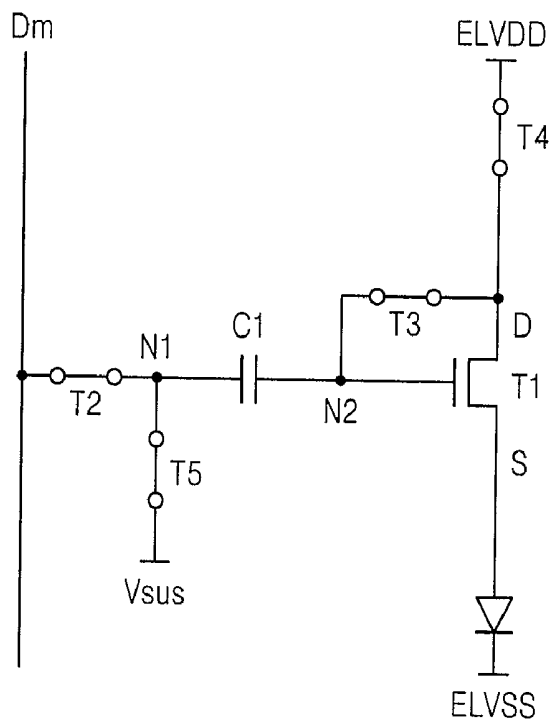

FIG. 8

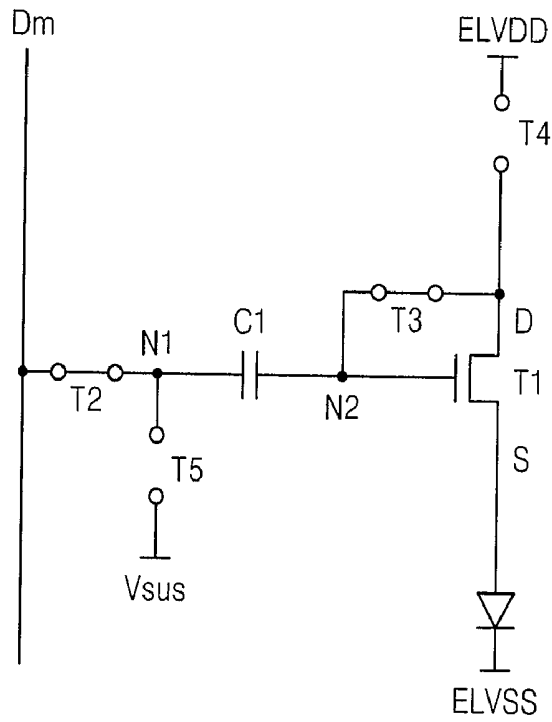

FIG. 9

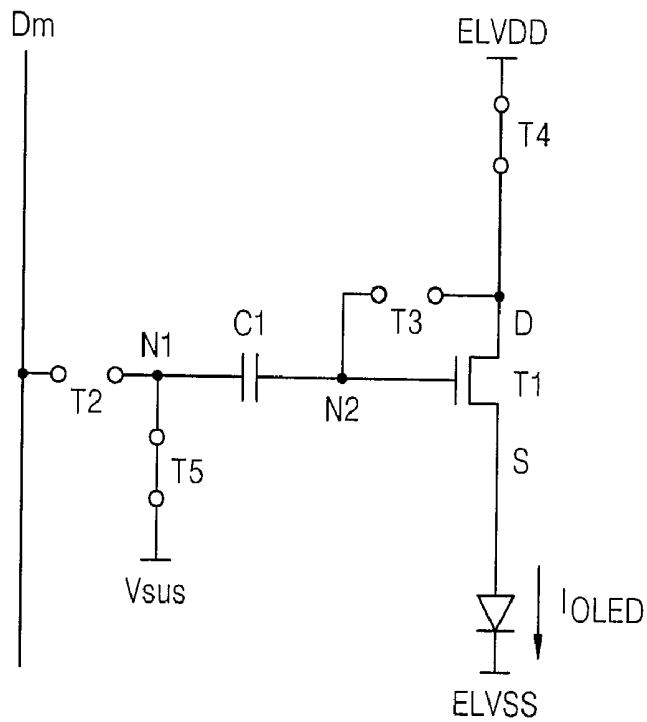

FIG. 10

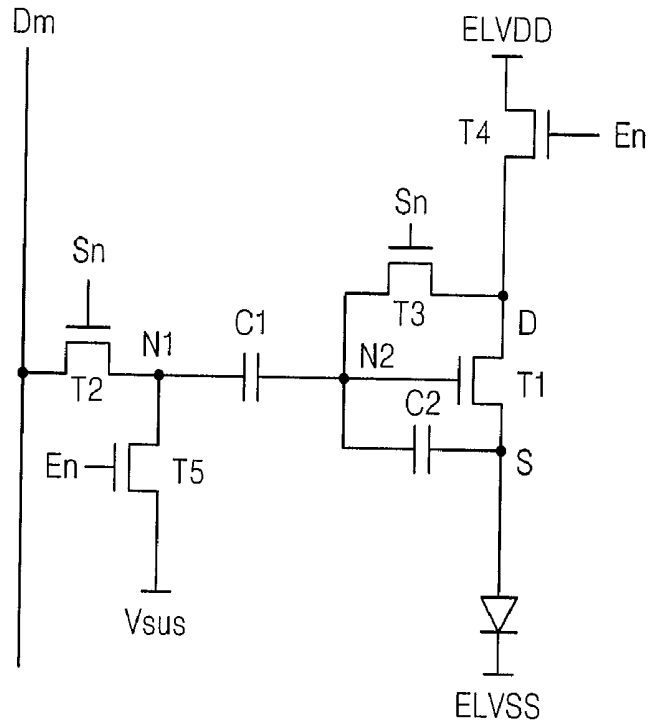

FIG. 11

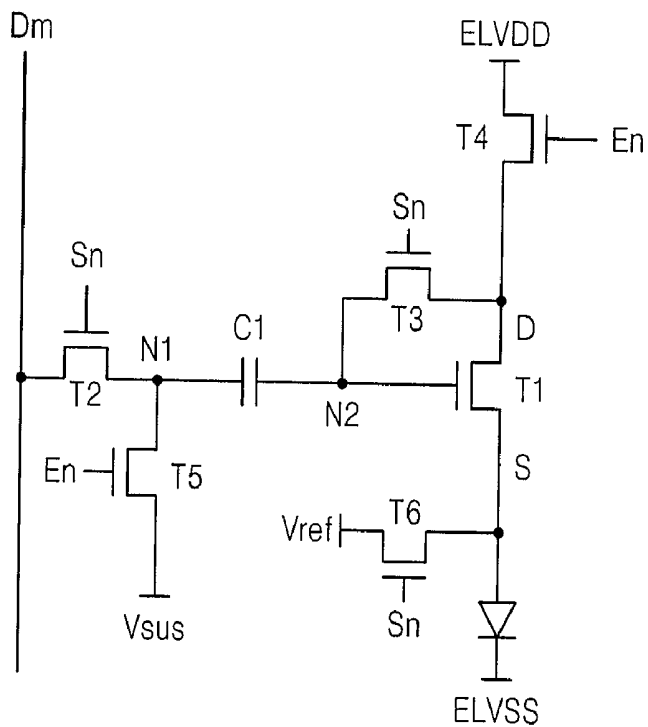

FIG. 12

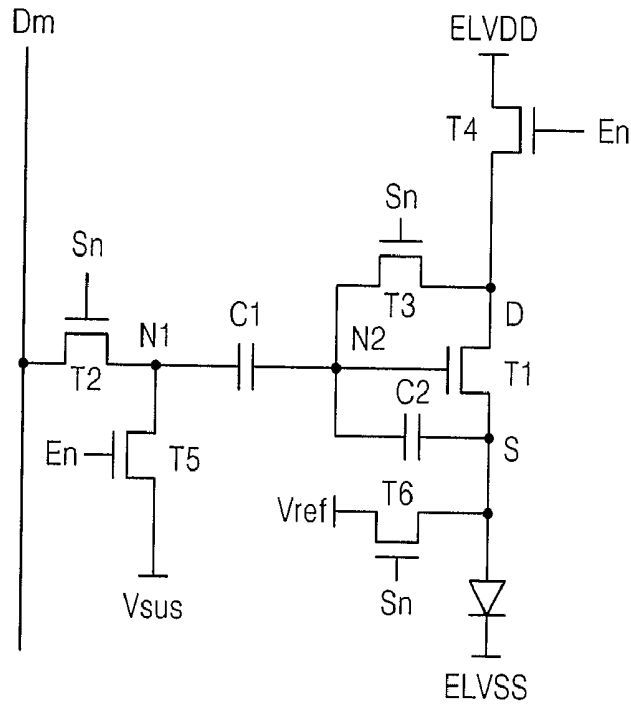

FIG. 13

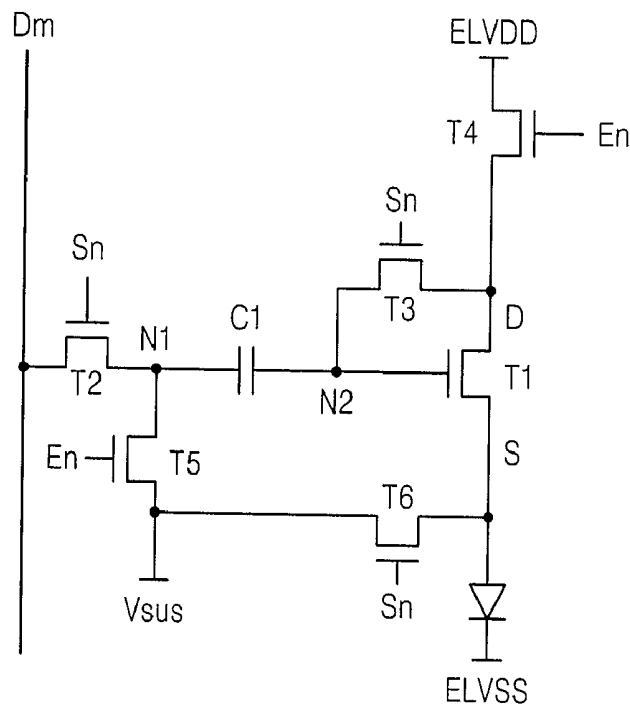

FIG. 14

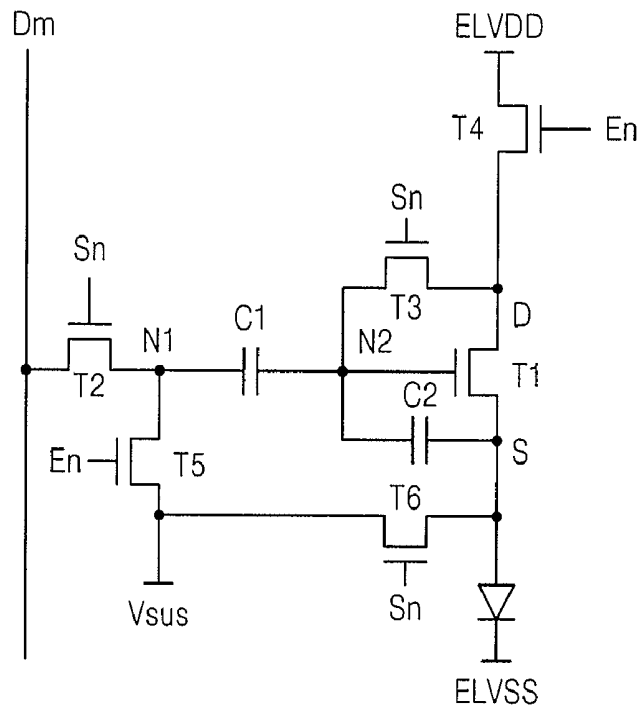
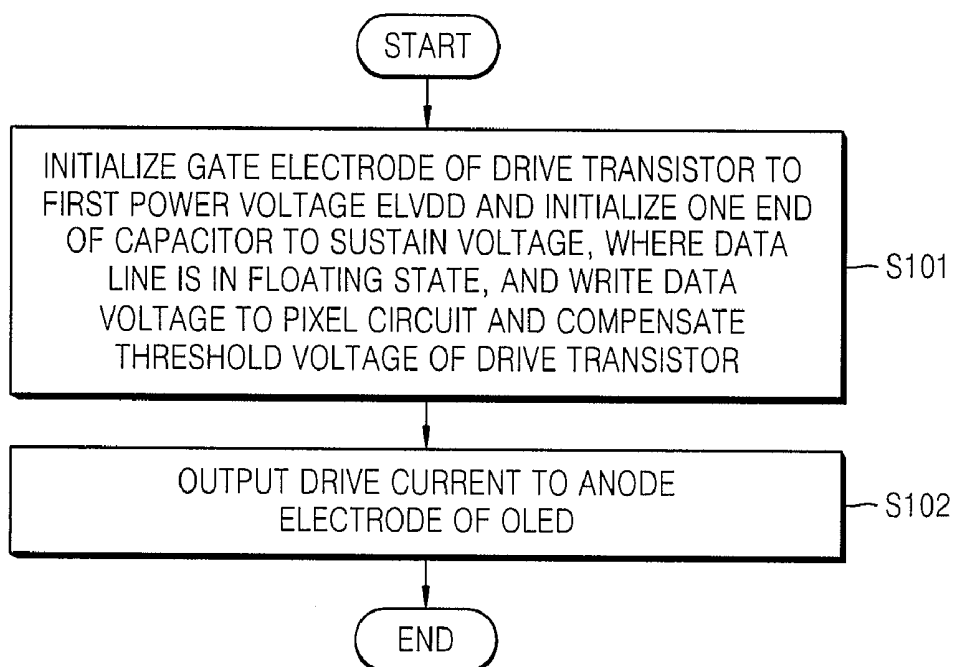

FIG. 15



**PIXEL CIRCUIT AND ORGANIC  
ELECTROLUMINESCENT DISPLAY  
APPARATUS USING THE SAME**

CROSS-REFERENCE TO RELATED  
APPLICATIONS

[0001] This application claims priority to and the benefit of Korean Patent Application No. 10-2009-0110361, filed on Nov. 16, 2009, in the Korean Intellectual Property Office, the disclosure of which is incorporated herein in its entirety by reference.

BACKGROUND

[0002] 1. Field

[0003] Aspects of embodiments of the present invention relate to a pixel circuit and an organic electroluminescent display apparatus using the pixel circuit.

[0004] 2. Description of the Related Art

[0005] An organic electroluminescent display apparatus displays an image by using organic light emitting diodes (OLEDs) which generate light by electron-hole recombination. The organic electroluminescent display apparatus has a fast response speed and low power consumption. In the organic electroluminescent display apparatus, a data driving signal corresponding to input data is applied to a plurality of pixel circuits to adjust brightness of each pixel, and the input data is converted to an image and provided to a viewer.

SUMMARY

[0006] Exemplary embodiments of the present invention provide a pixel circuit which may reduce the influence of the threshold voltage of a driving transistor and the second power voltage applied at the cathode electrode of an organic light emitting diode (OLED), on the drive current input to the OLED, when an organic electroluminescent display apparatus is implemented by using N-type transistors, and an organic electroluminescent display apparatus using the pixel circuit.

[0007] According to an embodiment of the present invention, a pixel circuit includes a light emitting device including a first electrode and a second electrode, a driving transistor including a first electrode and a second electrode and for outputting a drive current according to a voltage applied to a gate electrode of the driving transistor, a first capacitor including a first terminal and a second terminal coupled to the gate electrode of the driving transistor, a second transistor for transferring a data signal to the first terminal of the first capacitor in response to a scan control signal applied to a gate electrode of the second transistor, a third transistor for diode-connecting the driving transistor in response to the scan control signal applied to a gate electrode of the third transistor, a fourth transistor for applying a first power voltage to the first electrode of the driving transistor in response to an emission control signal, and a fifth transistor for applying a sustain voltage to the first terminal of the first capacitor in response to the emission control signal, in which the driving transistor and the second to fifth transistors are N-type transistors.

[0008] The second transistor may include a first electrode coupled to a data line and a second electrode coupled to the first electrode of the driving transistor, and the third transistor may include a first electrode coupled to the gate electrode of the driving transistor and a second electrode coupled to the first electrode of the driving transistor.

[0009] The light emitting device may include an organic light emitting diode (OLED).

[0010] The scan control signal and the emission control signal may be signals applied to a same row of pixels.

[0011] The driving transistor and the second, third, fourth, and fifth transistors may be N-type metal-oxide semiconductor field effect transistors (MOSFETs).

[0012] The first electrode of the driving transistor may be a drain electrode, and the second electrode of the driving transistor may be a source electrode.

[0013] The pixel circuit may further include a second capacitor including a first terminal coupled to the gate electrode of the driving transistor and a second terminal coupled to the first electrode of the light emitting device.

[0014] The pixel circuit may further include a sixth transistor for applying a reference voltage to the first electrode of the light emitting device in response to the scan control signal applied to a gate electrode of the sixth transistor.

[0015] The reference voltage may be substantially the same as the sustain voltage.

[0016] The scan control signal and the emission control signal may be driven in a first period, a second period, and a third period. In the first period, the scan control signal may be at a first level, and the emission control signal may be at the first level. In the second period, the data signal having an effective level may be applied to the pixel circuit, the scan control signal may be at the first level, and the emission control signal may be at a second level, and in the third period, the scan control signal may be at the second level, and the emission control signal may be at the first level, in which the first level is a level at which the driving transistor and the second, third, fourth, and fifth transistors are turned on, and the second level is a level at which the driving transistor and the second, third, fourth, and fifth transistors are turned off.

[0017] According to another embodiment of the present invention, an organic electroluminescent display apparatus includes a plurality of pixels, a first scan driver for outputting an emission control signal to each of the plurality of pixels and a second scan driver for outputting a scan control signal, and a data driver for generating a data signal and outputting the generated data signal to each of the plurality of pixels, in which each of the plurality of pixels includes an organic light emitting diode including an anode electrode and a cathode electrode, a driving transistor including a first electrode and a second electrode and for outputting a drive current according to a voltage applied to a gate electrode of the driving transistor, a first capacitor including a first terminal and a second terminal coupled to the gate electrode of the driving transistor, a second transistor for transferring the data signal to the first terminal of the first capacitor in response to the scan control signal applied to a gate electrode of the second transistor, a third transistor for diode-connecting the driving transistor in response to the scan control signal applied to a gate electrode of the third transistor, a fourth transistor for applying a first power voltage to the first electrode of the driving transistor in response to the emission control signal, and a fifth transistor for applying a sustain voltage to the first terminal of the first capacitor in response to the emission control signal, in which the driving transistor and the second, third, fourth, and fifth transistors are N-type transistors.

[0018] The scan control signal and the emission control signal may be signals applied to a same row of pixels.

[0019] The first electrode of the driving transistor may be a drain electrode, and the second electrode of the driving transistor may be a source electrode.

[0020] The organic electroluminescent display apparatus may further include a second capacitor including a first terminal coupled to the gate electrode of the driving transistor and a second terminal coupled to the anode electrode of the organic light emitting diode.

[0021] The organic electroluminescent display apparatus may further include a sixth transistor for applying a reference voltage to the anode electrode of the organic light emitting diode in response to the scan control signal applied to a gate electrode of the sixth transistor.

[0022] The reference voltage may be substantially the same as the sustain voltage.

[0023] The first scan driver and the second scan driver may be driven in a first period, a second period, and a third period. In the first period, the second scan driver may output the scan control signal at a first level, and the first scan driver may output the emission control signal at the first level. In the second period, the data driver may output the data signal having an effective level to the pixel circuit, the second scan driver may output the scan control signal at the first level, and the first scan driver may output the emission control signal at a second level, and in the third period, the second scan driver may output the scan control signal at the second level, and the first scan driver may output the emission control signal at the first level, in which the first level may be a level at which the driving transistor and the second to fifth transistors are turned on, and the second level may be a level at which the driving transistor and the second, third, fourth, and fifth transistors are turned off.

#### BRIEF DESCRIPTION OF THE DRAWINGS

[0024] The above and other features and aspects of the present invention will become more apparent by describing in detail exemplary embodiments thereof with reference to the attached drawings in which:

[0025] FIG. 1 is a diagram for illustrating the structure of an OLED;

[0026] FIG. 2 is a circuit diagram of a pixel circuit including P-type transistors;

[0027] FIG. 3 is a block diagram of an organic electroluminescent display apparatus according to an exemplary embodiment of the present invention;

[0028] FIG. 4 is a circuit diagram of a pixel circuit P of the organic electroluminescent display apparatus of FIG. 3;

[0029] FIG. 5 is a timing diagram of drive signals according to an exemplary embodiment of the present invention;

[0030] FIGS. 6, 7, 8, and 9 are circuit diagrams sequentially showing the operation of the pixel circuit of FIG. 4 according to the timing diagram of FIG. 5;

[0031] FIGS. 10, 11, 12, 13, and 14 are circuit diagrams showing the structures of pixel circuits according to other exemplary embodiments of the present invention; and

[0032] FIG. 15 is a flowchart for explaining a method of driving an organic electroluminescent display apparatus according to an exemplary embodiment of the present invention.

#### DETAILED DESCRIPTION

[0033] An organic electroluminescent display apparatus generates light by electrically exciting a fluorescent organic

compound. In the organic electroluminescent display apparatus, an image may be presented by driving a plurality of pixels arranged in a matrix format. The organic light emitting element included in the pixel has a diode characteristic and is referred to as an organic light emitting diode (OLED).

[0034] FIG. 1 conceptually illustrates the structure of an OLED. Referring to FIG. 1, the OLED has a structure including an anode electrode layer (Anode) formed of ITO, an organic thin layer, and a cathode electrode layer (Cathode) formed of metal. The organic thin layer may further include an emitting layer (EML), an electron transport layer (ETL), and a hole transport layer (HTL), to facilitate the balance between electrons and holes to improve light emitting efficiency. In addition, the organic thin layer may further include a hole injecting layer (HIL) or an electron injecting layer (EIL). The OLED may be driven by a thin film transistor (TFT) connected to the anode electrode of the OLED, according to a data voltage level that is stored in a capacitor connected to a gate electrode of TFT.

[0035] FIG. 2 is a circuit diagram of a pixel circuit including P-type transistors. Referring to FIG. 2, a switching transistor M2 is turned on by a selection signal from a selection scan line Sn. As the switching transistor M2 is turned on, a data voltage is transferred from a data line Dm to a gate electrode of a driving transistor M1. A potential difference between the data voltage and a first power voltage ELVDD is stored in a capacitor C1 that is connected between the gate electrode and a source electrode of the driving transistor M1. A drive current  $I_{OLED}$  flows through an OLED due to the potential difference so that the OLED may emit light. The OLED emits light with a brightness gradation according to the voltage level of the applied data voltage.

[0036] However, the driving transistor M1 of each pixel circuit may have a different threshold voltage among the pixel circuits. When the threshold voltages of the driving transistors M1 are different from each other, the amount of current output from the driving transistor M1 of each pixel circuit differs so that a uniform image may not be formed. The deviation in the threshold voltage of the driving transistor M1 may become severe as the size of the organic electroluminescent display apparatus increases, which may result in the deterioration of the image quality of the organic electroluminescent display apparatus. Thus, for the pixel circuit of the organic electroluminescent display apparatus to have a uniform image quality, the threshold voltage of the driving transistor M1 in the pixel circuit should be compensated for.

[0037] In the pixel circuit of FIG. 2, the switching transistor M2 and the driving transistor M1 are formed of PMOS transistors. One terminal of the capacitor C1 is connected to a source for supplying the first power voltage ELVDD, and the other terminal of the capacitor C1 is connected to a node A. The source electrode of the driving transistor M1 is connected to the source for supplying the first power voltage ELVDD, and a drain electrode of the driving transistor M1 is connected to an anode electrode of the OLED.

[0038] Here, the pixel circuit is configured to operate as a current source. The gate electrode of the driving transistor M1 is applied with the data voltage, and the source electrode of the driving transistor M1 is applied with the first power voltage ELVDD. That is, since the source electrode of the driving transistor M1 is fixed to the first power voltage ELVDD, the voltage has no influence on a change of a voltage  $V_{gs}$  during the light emission of the OLED.

[0039] In another pixel circuit, the switching transistor M2 and the driving transistor M1 of FIG. 2 are formed of N-type transistors. In this case, the capacitor C1 is connected between the gate electrode and the drain electrode of the driving transistor M1. Also, the voltage of the source electrode of the driving transistor M1 is not fixed and is connected as a source follower type to which a load is connected. Thus, the Vgs is affected by the second power voltage ELVSS via the OLED and the voltage across the OLED during the light emission of the OLED. The second power voltage ELVSS may be a cathode power voltage.

[0040] The second power voltage ELVSS varies according to an IR voltage drop due to a parasitic resistance element of a wiring for transferring the second power voltage ELVSS and a voltage drop due to the current flowing into each pixel. As a result, in the pixel circuit implemented with the N-type transistors, the voltage at the source electrode of the driving transistor is unstable so that brightness of an image may not be constant.

[0041] Also, in the pixel circuit implemented with the N-type transistors, the voltage across the OLED during the light emission of the OLED affects the Vgs. Thus, the pixel circuit may be sensitive to deviation of a characteristic of the OLED according to the temperature of the OLED and its deterioration.

[0042] The attached drawings illustrate exemplary embodiments of the present invention. Hereinafter, aspects of the present invention will be described in detail by explaining exemplary embodiments of the present invention with reference to the attached drawings. Like reference numerals in the drawings denote like elements.

[0043] FIG. 3 is a block diagram of an organic electroluminescent display apparatus 300 according to an exemplary embodiment of the present invention. Referring to FIG. 3, the organic electroluminescent display apparatus 300 includes a display unit 310, a first scan drive unit 302 (e.g., a first scan driver), a second scan drive unit 304 (e.g., a second scan driver), a data drive unit 306 (e.g., a data driver), and a power supply unit 308 (e.g., a power supply). The first scan drive unit 302, the second scan drive unit 304, the data drive unit 306, and the power supply unit 308 may be implemented as a single IC chip.

[0044] The display unit 310 includes  $n \times m$  number of pixel circuits P (P11, P12, P21, P22, . . . , and Pnm), each having an OLED (e.g., shown in FIG. 4),  $n$  number of scan lines provided in a row direction to transmit scan control signals S1, S2, . . . , and Sn,  $m$  number of data lines provided in a column direction to transmit data signals D1, D2, . . . , and Dm, and  $n$  number of emission control lines provided in the row direction to transmit emission control signals E1, E2, . . . , and En.

[0045] The pixel circuits P receive the first power voltage ELVDD, the second power voltage ELVSS, a sustain voltage V<sub>sus</sub>, and a reference voltage V<sub>ref</sub>, in addition to the scan control signals, the data signals, and the emission control signals, and form an image by driving the OLED provided in each pixel circuit P to emit light. According to another exemplary embodiment of the present invention, to reduce the number of wirings of power, the sustain voltage V<sub>sus</sub> instead of the reference voltage V<sub>ref</sub> may be applied to a node to which the reference voltage V<sub>ref</sub> is applied. According to the above described exemplary embodiment, the wirings for applying the reference voltage V<sub>ref</sub> may be reduced.

[0046] The first scan drive unit 302 is connected to the emission control lines and applies the emission control sig-

nals E1, E2, . . . , and En to the display unit 310. The second scan drive unit 304 is connected to the scan lines and applies the scan control signals S1, S2, . . . , Sn-1, and Sn to the display unit 310. The data drive unit 306 is connected to the data lines and applies the data signals D1, D2, . . . , and Dm to the display unit 310. The data drive unit 306 supplies data current to the pixel circuits P during a programming time. The power supply unit 308 supplies the first power voltage ELVDD, the second power voltage ELVSS, the sustain voltage V<sub>sus</sub>, and the reference voltage V<sub>ref</sub> to each of the pixel circuits P.

[0047] FIG. 4 is a circuit diagram of the pixel circuit P of the organic electroluminescent display apparatus of FIG. 3. Referring to FIG. 4, a pixel circuit P<sub>nm</sub> is located, for example, in the  $n$ -th row and the  $m$ -th column. The pixel circuit P<sub>nm</sub> receives the data signal D<sub>m</sub> through the data line from the data drive unit 306 and outputs drive current according to the data signal D<sub>m</sub> to the OLED. The pixel circuit P<sub>nm</sub> according to one exemplary embodiment includes a driving transistor T1, second, third, fourth, and fifth transistors T2, T3, T4, and T5, a light emitting device (e.g., OLED), and a capacitor C1.

[0048] The driving transistor T1 and the second to fifth transistors T2, T3, T4, and T5 included in the pixel circuit P<sub>nm</sub> may be N-type transistors such as N-type metal-oxide semiconductor field effect transistors (MOSFETs). The N-type transistor is turned on when a signal applied to a gate electrode is a high level (the first level) and turned off when the signal is a low level (the second level). A process for fabricating transistor using an oxide or amorphous-Si may be performed at a lower cost compared to a process using poly-Si. However, in a display panel formed primarily with oxide or amorphous-Si transistors, the pixel circuits are implemented with N-type transistors for which characteristic deviation of the N-type transistors is compensated for. Thus, in the exemplary embodiment of FIG. 4, a pixel circuit is formed of N-type transistors.

[0049] The driving transistor T1 includes a first electrode D corresponding to a drain electrode and a second electrode S corresponding to a source electrode, and outputs drive current according to the voltage applied to a gate electrode of the driving transistor T1. In the second transistor T2, the first electrode is connected to the data line, and the second electrode, which is connected with the first terminal of a first capacitor C1, is connected to a first node N1. The second transistor T2 transmits the data signal D<sub>m</sub> to the first node N1 in response to the scan control signal S<sub>n</sub> applied to the gate electrode of the second transistor T2.

[0050] In the third transistor T3, the first electrode, which is connected with the second electrode of the driving transistor T1, is connected to a second node N2, and the second electrode is connected to the first electrode of the driving transistor T1. The third transistor T3 diode-connects the driving transistor T1 in response to the scan control signal S<sub>n</sub> applied to the gate electrode of the third transistor T3.

[0051] In the fourth transistor T4, the first electrode receives the first power voltage ELVDD, and the second electrode is connected to the first electrode of the driving transistor T1. The fourth transistor T4 applies the first power voltage ELVDD to the first electrode of the driving transistor T1 in response to the emission control signal En.

[0052] In the fifth transistor T5, the first electrode, which is connected with the first electrode of the first capacitor, is connected to the first node N1, and the second electrode

receives the sustain voltage  $V_{sus}$ . The fifth transistor **T5** applies the sustain voltage  $V_{sus}$  to the first node **N1** in response to the emission control signal  $E_n$ .

**[0053]** In one embodiment, the light emitting device is an OLED and has the structure illustrated in FIG. 1. The OLED includes a first electrode corresponding to the anode electrode and a second electrode corresponding to the cathode electrode. According to the exemplary embodiment of FIG. 4, the anode electrode of the OLED is connected to the source electrode of the driving transistor **T1**, and the cathode electrode receives the second power voltage  $ELVSS$ . In the first capacitor **C1**, the first terminal is connected to the first node **N1**, and the second terminal is connected to the gate electrode of the driving transistor **T1**.

**[0054]** FIG. 5 is a timing diagram of drive signals according to an exemplary embodiment of the present invention. FIGS. 6-9 are circuit diagrams sequentially showing the operation of the pixel circuit of FIG. 4 according to the timing diagram of FIG. 5.

**[0055]** Referring to FIG. 5, in period (A), the scan control signal  $S_n$  has the second level (e.g., low level), and the emission control signal  $E_n$  has the first level (e.g., high level). Thus, the fourth and fifth transistors **T4** and **T5** are turned on, and the second and third transistors **T2** and **T3** are turned off.

**[0056]** FIG. 6 illustrates the operation of the pixel circuit in period (A). Referring to FIG. 6, the fourth transistor **T4** is turned on by the emission control signal  $E_n$ . Accordingly, drive current  $I_{OLED}$  corresponding to the data signal  $D_m$  of a previous frame, which is the voltage of the gate electrode of the driving transistor **T1** of a current frame, flows to the OLED so that the OLED may emit light. Also, since the fifth transistor **T5** is turned on, the sustain voltage  $V_{sus}$  is applied to one terminal of the first capacitor **C1** so that the first capacitor **C1** may maintain the gate voltage of the driving transistor **T1**.

**[0057]** Next, an initialization operation is performed in period (B). In period (B), both of the scan control signal  $S_n$  and the emission control signal  $E_n$  are in the second level. Thus, the second to fifth transistors **T2-T5** are all turned on.

**[0058]** FIG. 7 illustrates the operation of the pixel circuit in period (B). Referring to FIG. 7, in period (B), the third and fourth transistors **T3** and **T4** are turned on so that the gate electrode of the driving transistor **T1** may be initialized to the first power voltage  $ELVDD$ . Also, as the second to fifth transistors **T2-T5** are turned on, the first electrode of the second transistor **T2** is connected to the data line, and the sustain voltage  $V_{sus}$  connected to the second electrode of the fifth transistor **T5** is applied to the first node **N1**. Thus, the first node **N1** is initialized to the sustain voltage  $V_{sus}$ . Here, the data line does not output the data signal  $D_m$  and remains in a high impedance (Hi-Z) state, so as to prevent electrical short-circuit by the sustain voltage  $V_{sus}$  applied to the first node **N1**. In another example, the electrical connection between the data line and the pixel circuit during period (B) may be discontinued by forming a switching device between the data line and the output terminal of the data drive unit **306** outputting the data signal  $D_m$ .

**[0059]** Next, in period (C), the scan control signal  $S_n$  is maintained in the first level, and the emission control signal  $E_n$  is shifted to the second level. Accordingly, the second and third transistors **T2** and **T3** are turned on, whereas the fourth and fifth transistors **T4** and **T5** are turned off.

**[0060]** FIG. 8 illustrates the operation of the pixel circuit in period (C). Referring to FIG. 8, in period (C), data writing is

performed and the driving transistor **T1** is diode-connected so that the threshold voltage  $V_{th}$  of the driving transistor **T1** may be compensated for. As the second transistor **T2** is turned on, the data signal  $D_m$  of the current frame is applied so that the voltage of the first node **N1** becomes data voltage  $V_{data}$ . Also, the driving transistor **T1** is diode-connected by the third transistor **T3** so that a voltage as high as the threshold voltage  $V_{th}$  of the driving transistor **T1** may be applied to the first and second electrodes of the third transistor **T3**.

**[0061]** Next, in period (D), the scan control signal  $S_n$  maintains the second level. The emission control signal  $E_n$  is shifted to the first level. Thus, the fourth and fifth transistors **T4** and **T5** are turned on, and the second and third transistors **T2** and **T3** are turned off.

**[0062]** FIG. 9 illustrates the operation of the pixel circuit in period (D). Referring to FIG. 9, in period (D), current is applied to the OLED to emit light. As the fifth transistor **T5** is turned on, the voltage of the first node **N1** is changed from the data voltage  $V_{data}$  to the sustain voltage  $V_{sus}$ . As the voltage of the first node **N1** is changed from the  $V_{data}$  to the  $V_{sus}$ , the voltage of the second node **N2** is changed through the first capacitor **C1** as much as the amount of a voltage change of the first node **N1**, that is,  $V_{sus}-V_{data}$ . As a result, the voltage between the gate voltage and the source voltage of the driving transistor **T1** is  $(V_{sus}-V_{data})+V_{th}$ . Thus, drive current according to the voltage level corresponding to the difference between the gate voltage and the source voltage of the driving transistor **T1** is generated by the driving transistor **T1**. Since the fourth transistor **T4** is turned on, the OLED drive current flows through the driving transistor **T1** and the OLED. The voltage of the source electrode of the driving transistor **T1** is the same as that of the anode electrode of the OLED, and the voltage of the anode electrode of the OLED is  $ELVSS+V_{OLED}$ . The voltage  $V_{OLED}$  is a voltage across the OLED during the light emission of the OLED. Since the voltage of the gate electrode of the driving transistor **T1** is the voltage of the second node **N2**, the voltage of the gate electrode of the driving transistor **T1**  $V_g$  changes as expressed by Equation 1.

$$V_g = (V_{sus} - V_{data} + V_{th}) + (ELVSS + V_{OLED}) \quad \text{Equation 1}$$

**[0063]** Thus, in period (D), the  $V_g$ s of the driving transistor **T1** is as shown by Equation 2.

$$V_g = [(V_{sus} - V_{data} + V_{th}) + (ELVSS + V_{OLED})] - (ELVSS + V_{OLED}) \quad \text{Equation 2}$$

**[0064]** The drive current  $I_{OLED}$  determined by the  $V_g$ s is determined as shown in Equations 3 and 4. In Equations 3 and 4,  $k = \beta/2$ ,  $k$  is a constant,  $\beta$  is a gain factor.

$$I_{OLED} = k \{ [(V_{sus} - V_{data} + V_{th}) + (ELVSS + V_{oled}) - (ELVSS + V_{oled})] - V_{th} \}^2 \quad \text{Equation 3}$$

$$k [(V_{sus} - V_{data} + V_{th}) - V_{th}]^2$$

$$I_{OLED} = k (V_{sus} - V_{data})^2 \quad \text{Equation 4}$$

**[0065]** Thus, the drive current  $I_{OLED}$  output from the pixel circuit according to the exemplary embodiment of FIG. 4 is determined regardless of the voltage of the anode electrode of the OLED, the second power voltage  $ELVSS$ , and the threshold voltage  $V_{th}$  of the driving transistor **T1**. Accordingly, in exemplary embodiments of the present invention, since the amount of the drive current  $I_{OLED}$  is not changed by the voltage of the anode electrode of the OLED, an increase of the

voltage of the data signal  $D_m$  may be prevented and the deterioration of image quality may be prevented. Also, exemplary embodiments of the present invention may prevent the deterioration of the image quality due to the IR drop of the second power voltage ELVSS.

[0066] FIG. 10 is a circuit diagram showing the structure of a pixel circuit according to another exemplary embodiment of the present invention. Referring to FIG. 10, a second capacitor C2 charged with the threshold voltage  $V_{th}$  of the driving transistor T1 may be additionally provided between the gate electrode and the source electrode, which is connected to the anode electrode of the OLED, of the driving transistor T1. Thus, the method of driving a pixel circuit according to the exemplary embodiment of FIG. 10 is the same as the method illustrated in reference to FIG. 4. When the OLED emits light, the second capacitor C2 functions as an additional storage capacitor, together with the first capacitor C1.

[0067] FIG. 11 is a circuit diagram showing the structure of a pixel circuit according to another exemplary embodiment of the present invention. Referring to FIG. 11, an electrode of a sixth transistor T6 is connected between the source electrode of the driving transistor T1 and the anode electrode of the OLED. The sixth transistor T6 applies the reference voltage  $V_{ref}$  to the source electrode of the driving transistor T1 in response to the scan control signal  $S_n$ . According to the exemplary embodiment of FIG. 11, the sixth transistor T6 is turned on when the scan control signal is shifted to the first level in periods (B) and (C). The source voltage of the driving transistor T1 is fixed to the reference voltage  $V_{ref}$ . That is, the sixth transistor T6 functions to fix the source voltage of the driving transistor T1 during the initialization of the pixel circuit, the data writing, and the compensation of the threshold voltage  $V_{th}$  of the driving transistor T1 according to the embodiment of FIG. 11. The value of the reference voltage  $V_{ref}$  should be less than the sum of the second power voltage ELVSS and the threshold voltage of the OLED. If the value of the reference voltage  $V_{ref}$  is greater than the sum of the second power voltage ELVSS and the threshold voltage of the OLED, during the initialization of the pixel circuit, the data writing, and the compensation of the threshold voltage  $V_{th}$  of the driving transistor T1, current flows through the OLED due to the voltage difference across its anode and cathode electrodes so that the OLED may emit light undesirably.

[0068] FIG. 12 is a circuit diagram showing the structure of a pixel circuit according to another exemplary embodiment of the present invention. Referring to FIG. 12, both of the second capacitor C2 of FIG. 10 and the sixth transistor T6 of FIG. 11 are added to the pixel circuit. Thus, since the driving method is the same as those described with reference to FIGS. 10 and 11, a detailed description thereof will be omitted herein.

[0069] FIG. 13 is a circuit diagram showing the structure of a pixel circuit according to another exemplary embodiment of the present invention. Referring to FIG. 13, the sixth transistor T6 is connected to the source electrode of the driving transistor T1. The sixth transistor T6 applies the sustain voltage  $V_{sus}$  to the source electrode of the driving transistor T1 in response to the scan control signal. The sustain voltage  $V_{sus}$  replaces the reference voltage  $V_{ref}$ , as illustrated in the FIG. 12. Thus, the number of power sources and wirings may be reduced.

[0070] FIG. 14 is a circuit diagram showing the structure of a pixel circuit according to another exemplary embodiment of the present invention. Referring to FIG. 14, the sixth transis-

tor T6 connected to apply the sustain voltage  $V_{sus}$  as shown in FIG. 13 is added to the pixel circuit of FIG. 12.

[0071] FIG. 15 is a flowchart for explaining a method of driving an organic electroluminescent display apparatus according to an exemplary embodiment of the present invention. Referring to FIG. 15, an operation S101 corresponds to periods (B) and (C) of FIG. 5. First, the gate electrode of the driving transistor T1 is initialized to the first power voltage ELVDD in response to the scan control signal  $S_n$ . Also, one terminal of the capacitor C1 included in the pixel circuit is initialized to the sustain voltage  $V_{sus}$ . The data line for applying the data signal  $D_m$  to the pixel circuit may be in a floating state.

[0072] Also, in response to the scan control signal  $S_n$ , the data signal  $D_m$  is applied to the pixel circuit through the second transistor T2, and the third transistor T3 is turned on to diode-connect the driving transistor T1 to compensate for the threshold voltage of the driving transistor T1. In more detail, the first capacitor C1 is charged with a voltage corresponding to the difference between the data voltage and the threshold voltage of the driving transistor T1.

[0073] An operation S102 corresponds to period (D) of FIG. 5. In response to the emission control signal  $E_n$ , the fifth transistor T5 is turned on and the sustain voltage  $V_{sus}$  is applied to the pixel circuit so that the gate voltage of the driving transistor T1 may be changed accordingly. Also, the drive current  $I_{OLED}$  is output to the anode electrode of the OLED. The amount of the drive current  $I_{OLED}$  is determined according to the voltage level  $V_{data}$  of the data signal  $D_m$  stored in the capacitor C1, as expressed by Equation 4. Accordingly, the OLED may emit light having a brightness corresponding to the amount of the drive current  $I_{OLED}$ .

[0074] As described above, according to the exemplary embodiments of the present invention, since the drive current input to the OLED is determined regardless of the threshold voltage of the driving transistor and the second power voltage applied at the cathode of the OLED, the IR drop generated due to the deviation in the threshold voltage of the driving transistor and the parasitic resistance element of the wiring for transferring the second power voltage may be prevented or reduced. Also, the number of wirings applied to each pixel circuit may be reduced.

[0075] While this invention has been particularly shown and described with reference to exemplary embodiments thereof, it will be understood by those skilled in the art that various changes in form and details may be made therein without departing from the spirit and scope of the present invention as defined by the appended claims and their equivalents.

What is claimed is:

1. A pixel circuit comprising:
  - a light emitting device comprising a first electrode and a second electrode;
  - a driving transistor comprising a first electrode and a second electrode and for outputting a drive current according to a voltage applied to a gate electrode of the driving transistor;
  - a first capacitor comprising a first terminal and a second terminal coupled to the gate electrode of the driving transistor;
  - a second transistor for transferring a data signal to the first terminal of the first capacitor in response to a scan control signal applied to a gate electrode of the second transistor;

- a third transistor for diode-connecting the driving transistor in response to the scan control signal applied to a gate electrode of the third transistor;
- a fourth transistor for applying a first power voltage to the first electrode of the driving transistor in response to an emission control signal; and
- a fifth transistor for applying a sustain voltage to the first terminal of the first capacitor in response to the emission control signal,
- wherein the driving transistor and the second to fifth transistors are N-type transistors.
2. The pixel circuit of claim 1, wherein the second transistor comprises a first electrode coupled to a data line and a second electrode coupled to the first electrode of the driving transistor, and
- wherein the third transistor comprises a first electrode coupled to the gate electrode of the driving transistor and a second electrode coupled to the first electrode of the driving transistor.
3. The pixel circuit of claim 1, wherein the light emitting device comprises an organic light emitting diode (OLED).
4. The pixel circuit of claim 1, wherein the scan control signal and the emission control signal are signals applied to a same row of pixels.
5. The pixel circuit of claim 1, wherein the driving transistor and the second, third, fourth, and fifth transistors are N-type metal-oxide semiconductor field effect transistors (MOSFETs).
6. The pixel circuit of claim 1, wherein the first electrode of the driving transistor is a drain electrode, and the second electrode of the driving transistor is a source electrode.
7. The pixel circuit of claim 1, further comprising a second capacitor comprising a first terminal coupled to the gate electrode of the driving transistor and a second terminal coupled to the first electrode of the light emitting device.
8. The pixel circuit of claim 1, further comprising a sixth transistor for applying a reference voltage to the first electrode of the light emitting device in response to the scan control signal applied to a gate electrode of the sixth transistor.
9. The pixel circuit of claim 8, wherein the reference voltage is substantially the same as the sustain voltage.
10. The pixel circuit of claim 1, wherein the scan control signal and the emission control signal are driven in a first period, a second period, and a third period,
- in the first period, the scan control signal is at a first level, and the emission control signal is at the first level;
- in the second period, the data signal having an effective level is applied to the pixel circuit, the scan control signal is at the first level, and the emission control signal is at a second level; and
- in the third period, the scan control signal is at the second level, and the emission control signal is at the first level, and
- wherein the first level is a level at which the driving transistor and the second to fifth transistors are turned on, and the second level is a level at which the driving transistor and the second to fifth transistors are turned off.
11. An organic electroluminescent display apparatus comprising:
- a plurality of pixels;
- a first scan driver for outputting an emission control signal to each of the plurality of pixels and a second scan driver for outputting a scan control signal; and
- a data driver for generating a data signal and outputting the generated data signal to each of the plurality of pixels, wherein each of the plurality of pixels comprises:
- an organic light emitting diode comprising an anode electrode and a cathode electrode;
- a driving transistor comprising a first electrode and a second electrode and for outputting a drive current according to a voltage applied to a gate electrode of the driving transistor;
- a first capacitor comprising a first terminal and a second terminal coupled to the gate electrode of the driving transistor;
- a second transistor for transferring the data signal to the first terminal of the first capacitor in response to the scan control signal applied to a gate electrode of the second transistor;
- a third transistor for diode-connecting the driving transistor in response to the scan control signal applied to a gate electrode of the third transistor;
- a fourth transistor for applying a first power voltage to the first electrode of the driving transistor in response to the emission control signal; and
- a fifth transistor for applying a sustain voltage to the first terminal of the first capacitor in response to the emission control signal, and
- wherein the driving transistor and the second to fifth transistors are N-type transistors.
12. The organic electroluminescent display apparatus of claim 11, wherein the scan control signal and the emission control signal are signals applied to a same row of pixels.
13. The organic electroluminescent display apparatus of claim 11, wherein the first electrode of the driving transistor is a drain electrode, and the second electrode of the driving transistor is a source electrode.
14. The organic electroluminescent display apparatus of claim 11, further comprising a second capacitor comprising a first terminal coupled to the gate electrode of the driving transistor and a second terminal coupled to the anode electrode of the organic light emitting diode.
15. The organic electroluminescent display apparatus of claim 11, further comprising a sixth transistor for applying a reference voltage to the anode electrode of the organic light emitting diode in response to the scan control signal applied to a gate electrode of the sixth transistor.
16. The organic electroluminescent display apparatus of claim 15, wherein the reference voltage is substantially the same as the sustain voltage.
17. The organic electroluminescent display apparatus of claim 11, wherein the first scan drive unit and the second scan drive unit are driven in a first period, a second period, and a third period,
- the second scan driver is configured to output in the first period the scan control signal at a first level, and the first scan driver is configured to output in the first period the emission control signal at the first level;
- the data driver is configured to output in the second period the data signal having an effective level to the pixel circuit, the second scan driver is configured to output in

the second period the scan control signal at the first level, and the first scan driver is configured to output in the second period the emission control signal at a second level; and  
the second scan driver is configured to output in the third period the scan control signal at the second level, and the first scan driver is configured to output in the third period the emission control signal at the first level, and

wherein the first level is a level at which the driving transistor and the second, third, fourth, and fifth transistors are turned on, and the second level is a level at which the driving transistor and the second, third, fourth, and fifth transistors are turned off.

\* \* \* \* \*

专利名称(译)	像素电路和使用它的有机电致发光显示设备		
公开(公告)号	<a href="#">US20110115772A1</a>	公开(公告)日	2011-05-19
申请号	US12/832935	申请日	2010-07-08
[标]申请(专利权)人(译)	CHUNG KYUNG HOON		
申请(专利权)人(译)	CHUNG京勋		
当前申请(专利权)人(译)	CHUNG京勋		
[标]发明人	CHUNG KYUNG HOON		
发明人	CHUNG, KYUNG-HOON		
IPC分类号	G09G3/30 G09G5/00		
CPC分类号	G09G3/3233 G09G2300/0819 G09G2300/0842 G09G2320/043 G09G2300/0861 G09G2320/0223 G09G2300/0852		
优先权	1020090110361 2009-11-16 KR		
其他公开文献	US8552943		
外部链接	<a href="#">Espacenet</a> <a href="#">USPTO</a>		

摘要(译)

提供了一种改进的像素电路。像素电路包括根据施加到驱动晶体管的栅电极的电压由驱动电流驱动的发光器件。像素电路还包括第一电容器，第二晶体管，用于响应于施加到第二晶体管的栅极的扫描控制信号将数据信号传送到第一电容器的第一端子，第三晶体管用于二极管连接第二晶体管。响应于施加到第三晶体管的栅极的扫描控制信号驱动晶体管，响应于发射控制信号将第一电源电压施加到驱动晶体管的第一电极的第四晶体管，以及用于施加的第五晶体管响应于发射控制信号，向第一电容器的第一端子提供维持电压。驱动晶体管和第二至第五晶体管是N型晶体管。

